

PRELIMINARY DRAWING

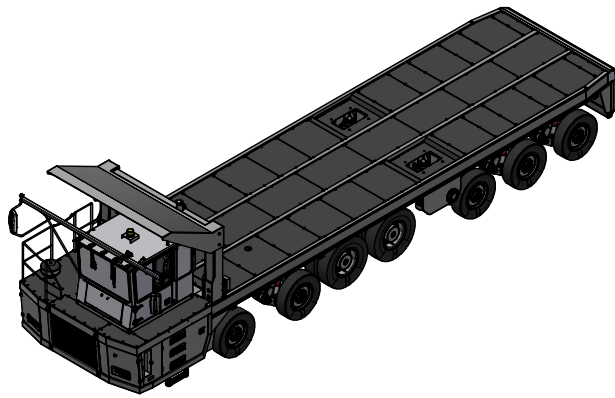

R 37' 10"
(R 11,52 m)

R 36' 1"
(R 10,98 m)

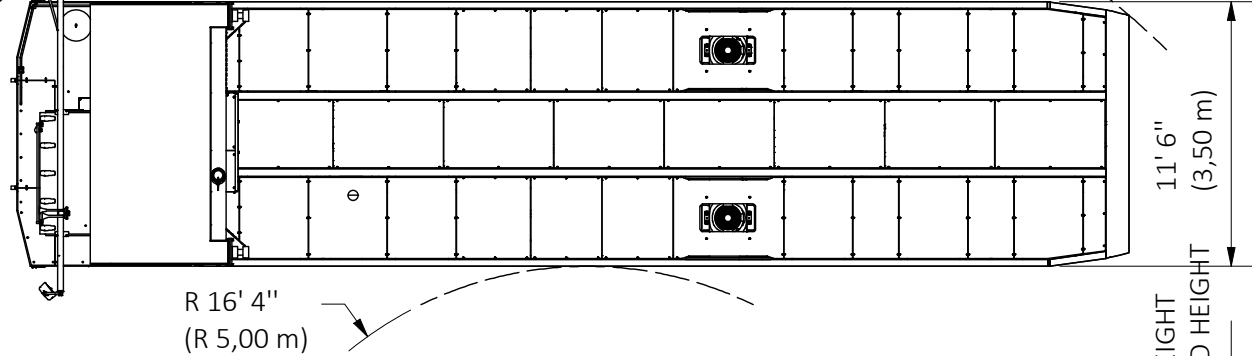

R 16' 4"
(R 5,00 m)

11' 6"
(3,50 m)

14' 7" (4,45 m)

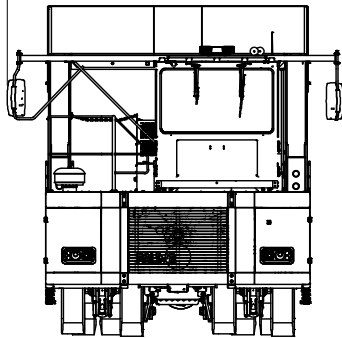

14' 4" (4,37 m)

48' 6" (14,79 m)

38' 2" (11,65 m)

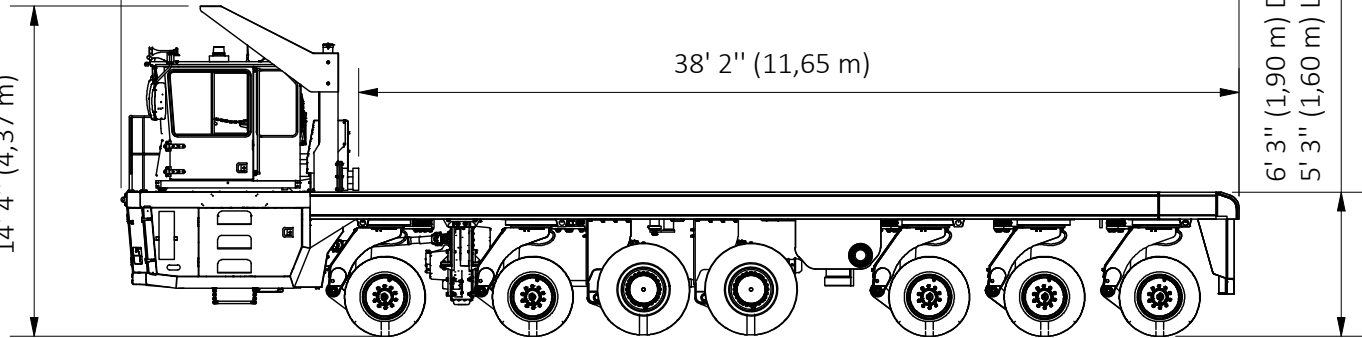

6' 3" (1,90 m) DRIVE HEIGHT
5' 3" (1,60 m) LOWERED HEIGHT

SHOWN IN DRIVE HEIGHT

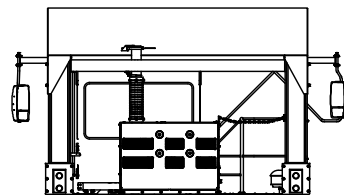

U.S EPA TIER 4 EMISSION / EU STAGE V
CLEAN EMISSION MODULE (CEM)

TRANSPORTER SPECIFICATIONS:

- PAYLOAD CAPACITY: 175 TONS
- EMPTY VEHICLE WEIGHT (EVW): 55 TONS
- GROSS VEHICLE WEIGHT (GVW): 230 TONS
- AXLE LINES: 7 - 2 DRIVEN & 5 STEERING AXLE
- LINE LOAD AT GVW: 32.9 TONS
- TIRE LOAD AT GVW: 8.2 TONS
- GROUND PRESSURE AT GVW: 120 PSI



PALING
TRANSPORTER LTD.

1632 BURLINGTON STREET EAST, HAMILTON, ON L8H 3L3, CANADA

THIS PRINT IS EXCLUSIVELY THE PROPERTY OF PALING TRANSPORTER AND IT IS NOT TO BE REPRODUCED, COPIED OR DISCLOSED TO ANYONE WITHOUT PALING TRANSPORTER'S WRITTEN PERMISSION.

TITLE: CTS 175D TRANSPORTER - 17572-138-T4

SCALE: 1 / 100

DATE: 2025-01-13

DESIGNED: BOB C.

CHECKED: ANKIT L.

DRAWN: KEVIN D.

APPROVED: RICCARDO B.

QUOTE NO.

SHEET
1 OF 6

PRELIMINARY DRAWING

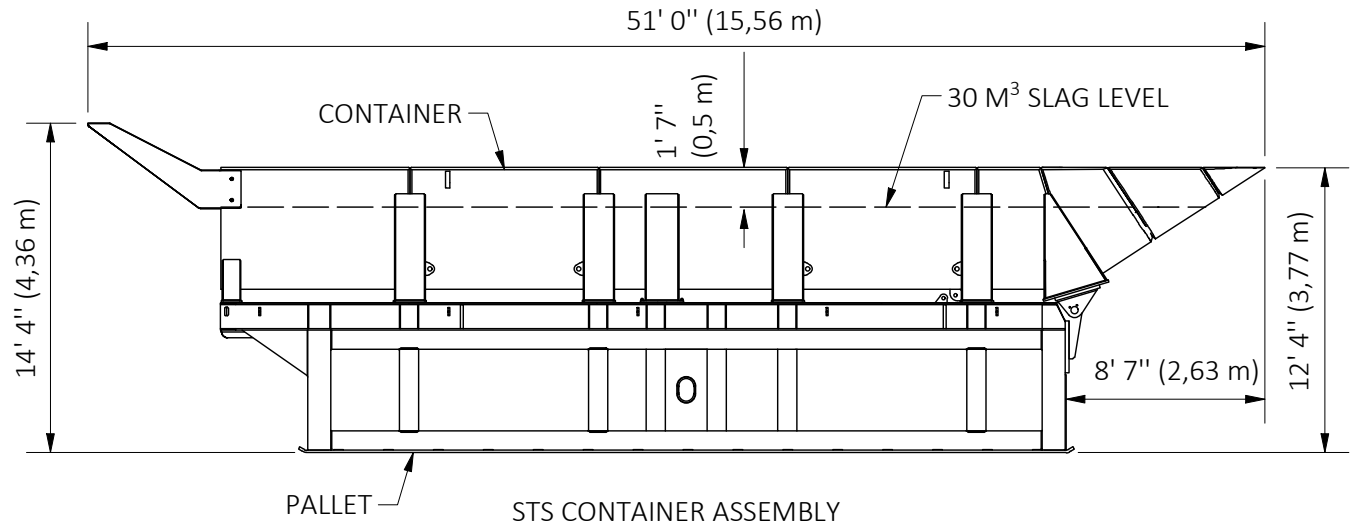
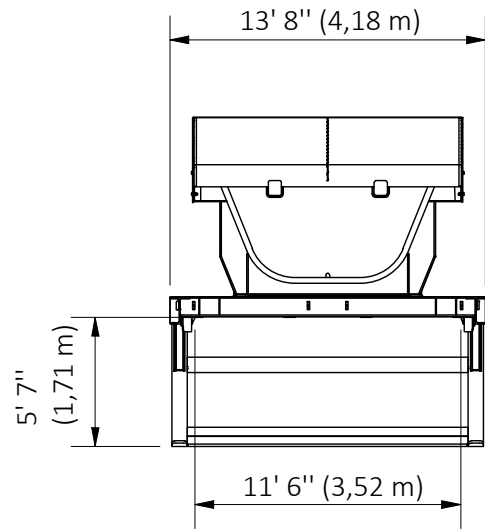
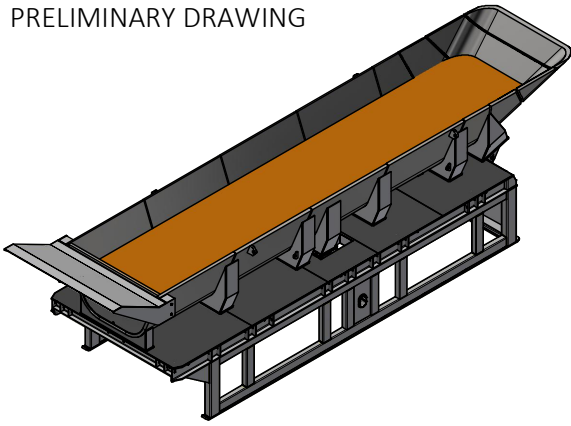

STS40 SLAG CONTAINER DOORLESS SPECIFICATIONS:

- A CONTAINER TOTAL VOLUME CAPACITY: 40M³
- CONTAINER DESIGN VOLUME: 30M³
- CONTAINER WEIGHT: 80 TONS
- CONTAINER PAYLOAD CAPACITY: 95 TONS



1632 BURLINGTON STREET EAST, HAMILTON, ON L8H 3L3, CANADA

THIS PRINT IS EXCLUSIVELY THE PROPERTY OF PALING TRANSPORTER AND IT IS NOT TO BE REPRODUCED, COPIED OR DISCLOSED TO ANYONE WITHOUT PALING TRANSPORTER'S WRITTEN PERMISSION.

TITLE: STS40 SLAG CONTAINER DOORLESS

SCALE: 1 / 100 DATE: 2025-01-13

DESIGNED: BOB C. CHECKED: ANKIT L.

DRAWN: KEVIN D. APPROVED: RICCARDO B.

QUOTE NO. SHEET 2 OF 6

PRELIMINARY DRAWING

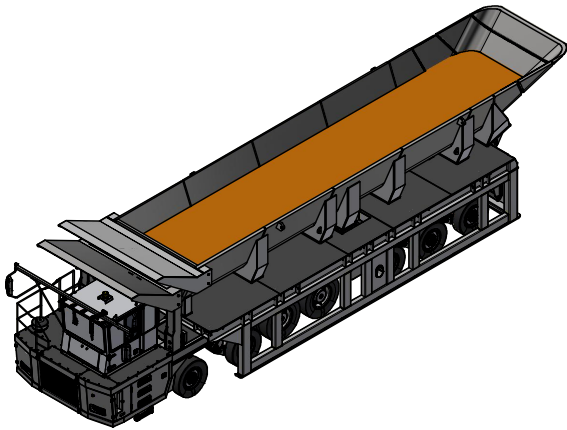

R 37' 10"
(R11,52 m)

R 41' 5"
(R12,62 m)

R 15' 4"
(R4,66 m)

57' 2" (17,42 m)

14' 11" (4,55 m)

8' 7" (2,63 m)

13' 0" (3,97 m)

GROUND CLEARANCE 8" (0.2 m)

SHOWN IN DRIVE HEIGHT

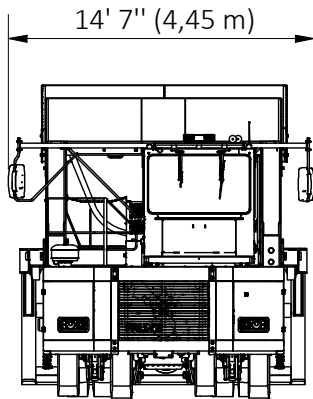

14' 7" (4,45 m)

SLAG TRANSPORT SYSTEM SPECIFICATIONS:
POWER UNIT: CTS 175D TRANSPORTER - 17572-138-T4
CONTAINER: STS40 SLAG CONTAINER DOORLESS



PALING
TRANSPORTER LTD.

1632 BURLINGTON STREET EAST, HAMILTON, ON L8H 3L3, CANADA

THIS PRINT IS EXCLUSIVELY THE PROPERTY OF PALING TRANSPORTER AND IT IS NOT TO BE REPRODUCED, COPIED OR DISCLOSED TO ANYONE WITHOUT PALING TRANSPORTER'S WRITTEN PERMISSION.

TITLE: SLAG TRANSPORT SYSTEM - CTS 175D / STS40 DOORLESS

SCALE: 1 / 110

DATE: 2025-01-13

DESIGNED: BOB C.

CHECKED: ANKIT L.

DRAWN: KEVIN D.

APPROVED: RICCARDO B.

QUOTE NO.

SHEET
3 OF 6

PRELIMINARY DRAWING

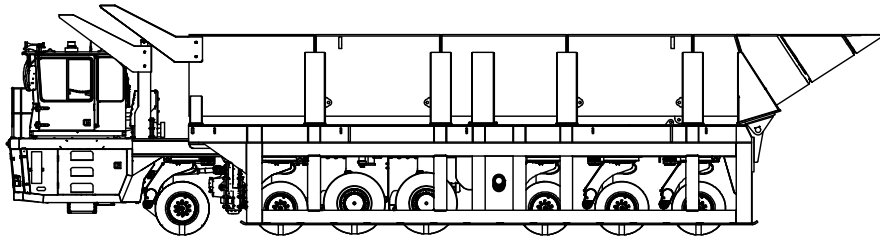

SHOWN IN DRIVE HEIGHT

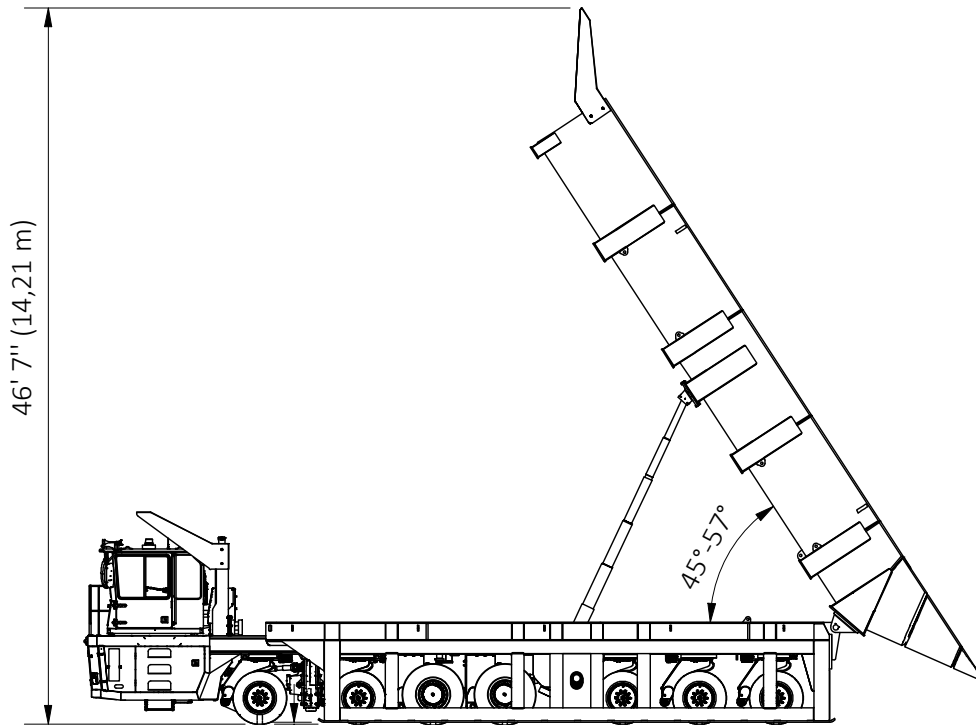

46' 7" (14,21 m)

45°-57°

8 INCHES GROUND CLEARANCE

SHOWN IN DUMPING POSITION



PALING
TRANSPORTER LTD.

1632 BURLINGTON STREET EAST, HAMILTON, ON L8H 3L3, CANADA

THIS PRINT IS EXCLUSIVELY THE PROPERTY OF PALING TRANSPORTER AND IT IS NOT TO BE REPRODUCED, COPIED OR DISCLOSED TO ANYONE WITHOUT PALING TRANSPORTER'S WRITTEN PERMISSION.

TITLE: SLAG TRANSPORT SYSTEM - CTS 175D / STS40 DOORLESS

SCALE: 1 / 150

DATE: 2025-01-13

DESIGNED: BOB C.

CHECKED: ANKIT L.

DRAWN: KEVIN D.

APPROVED: RICCARDO B.

QUOTE NO.

SHEET
4 OF 6